

C500 10-20kVA



Tower 6-10kVA

Installation/Manual

Service and support
WWW.CERTAUPS.COM
INFO@CERTAUPS.COM
T: +44 (0)1246 431 431

CertaUPS



Parallel connection



High efficiency up to 97%



Intelligent communications



Maintenance bypass switch



Pure sine-wave output



Smart opp monitoring



USB connectivity & I11D support



Online double conversion



Virtualization compatible



Eco-mode function



Dual input



Additional battery connection

CONTENT:

1. Safety and EMC Instructions	0
1.1 Installation	0
1.2 Operation	1
1.3 Maintenance, servicing and faults	1
1.4 Transport.....	3
1.5 Storage	3
1.6 Standards	4
2. Description of Commonly Used Symbols	5
3. Introduction	5
3.1 Feature.....	6
3.2 Electrical specifications.....	6
3.3 Operating Environment.....	8
3.4 Typical backup time (Typical values at 25°C in minutes).....	8
3.5 Dimensions and weights	9
4. Installation	11
4.1 Moving to the installation site	11
4.2 Unpacking and inspection.....	11
4.3 Input and output power wires and protective earth ground installation	12
4.4 Operating procedure for connecting with the external battery	16
4.5 EPO Connection	18
5. Operation	18
5.1 Display Panel	18
5.2 Operating mode.....	22
5.3 Turning on and Turning off UPS	28
5.4 LCD operation	30
6. Special function	38
6.1 HE function	38
6.2 Converter function.....	39
6.3 Parallel function	39
7. Trouble Shooting	44

7.1 Trouble Shooting According To Warning Indication.....	45
7.2 Trouble Shooting According To Fault Indication.....	46
7.3 Trouble Shooting In Else Cases.....	47
8. Battery Maintenance	48
9. Communication Port.....	49
9.1 USB Interface	49
9.2 RS-232 Interface.....	50
9.3 Dry contact Interface	52
10. Software	53

1. Safety and EMC Instructions

Please read carefully the following user manual and the safety instructions before installing the unit or using the unit!

1.1 Installation

- This is permanently connected equipment, and it must be installed by qualified maintenance personnel.
- Condensation may occur if the UPS is moved directly from a cold to a warm environment. The UPS must be absolutely dry before being installed. Please allow an acclimatization time of at least two hours.
- Do not install the UPS near water or in a damp environment.
- Do not install the UPS where it will be exposed to direct sunlight or positioned near a source of heat.
- Do not connect appliances or items of equipment which will overload the UPS (e.g. laser printers, etc) to the UPS output.
- Place cables in such a way that no one can step on or trip over them.
- Connect the UPS to with the earth reliably before connecting to the building wiring terminal. The external battery source must also be correctly earthed.
- An integral single emergency switching device which prevents further supply to the load by the UPS in any mode of operation should be provided in the building wiring installation.
- An appropriate disconnect device as short-circuit backup protection should be provided in the building wiring installation.

- The equipment is powered by two sources:
- The mains source and either the internal or external battery source.
- Ensure that with the installation of the equipment, the sum of the leakage current of the UPS and the connected load does not exceed 5% of rated value of input current.
- Do not block ventilation openings in the UPS's housing. Ensure that at least 50cm of space is left to the front and rear of the UPS.

1.2 Operation

- Do not disconnect the mains cable on the UPS or the building wiring terminals during operation as this will remove the protective earth from the UPS and all connected loads.
- The UPS output terminal block may still be electrically live even if the UPS is not connected to the building wiring terminal, as there is an internal current source (batteries).
- In order to fully disconnect the UPS, first turn the input breaker to the "OFF" position, once done, disconnect the mains lead.
- Indiscriminate operation of switches may cause output loss or damage to equipment. Refer to instructions before conducting any control.
- While the UPS is connected in a parallel system, the external parallel cable should have reinforced insulation.
- Ensure that no liquid or other foreign objects can enter the UPS.

1.3 Maintenance, servicing and faults

- Do not remove the enclosure since the UPS operates with hazardous voltages. It is to be serviced only by qualified maintenance personnel.

- Caution - risk of electric shock. Even after the unit is disconnected from the mains power supply (building wiring terminal), components inside the UPS are still connected to the battery which could present a potential hazard.
- Before carrying out any kind of service and/or maintenance, isolate the UPS and disconnect the batteries. Verify that no current is present and no hazardous voltage exists in either the capacitor or the BUS capacitor.
- Batteries must be replaced only by qualified personnel.
- Batteries have a high short-circuit current and pose a risk of electric shock. Take all precautionary measures, specifically those listed below, when working with batteries:
 - — remove all jewellery, wristwatches, rings and other metal objects
 - — use only tools with insulated grips and handles.
- When changing batteries, replace with the same quantity and the same type of batteries.
- Batteries should not be disposed of in a fire, as this could be potentially very hazardous. Please dispose of batteries appropriately.
- The UPS may be connected to external battery module (EBM). Proper disposal of batteries is required. Refer to your local codes for disposal requirements.

- Do not open or destroy batteries. These batteries contain effluent electrolyte which can cause serious injury to the skin and eyes. It may also be toxic.
- Replace the fuse only with a fuse of the same type and specification in order to avoid fire hazards.

1.4 Transport

- Please transport the UPS only in the original packaging to protect against shock and impact.

1.5 Storage









- The UPS must be stored in a room which is ventilated and dry.

1.6 Standards

* Safety	
IEC/EN 62040-1	
* EMI	
Conducted Emission.....:IEC/EN 62040-2	Category C3
Radiated Emission.....:IEC/EN 62040-2	Category C3
* EMS	
ESD.....:IEC/EN 61000-4-2	Level 3
RS.....:IEC/EN 61000-4-3	Level 3
EFT.....:IEC/EN 61000-4-4	Level 4
SURGE.....:IEC/EN 61000-4-5	Level 4
CS.....:IEC/EN 61000-4-6	Level 3
MS.....: IEC/EN 61000-4-8	Level 3
Voltage Dips.....: IEC/EN 61000-4-11	
Low Frequency Signals.....:IEC/EN 61000-2-2	
Warning: This is a product for commercial applications. If used in an industrial environment extra precautions may be required.	

2. Description of Commonly Used Symbols

Some or all of the following symbols may be used in this manual. It is advisable to familiarize yourself with them and understand their meaning:

Symbol and Explanation			
Symbol	Explanation	Symbol	Explanation
	Alert you to pay special attention		Direct current source (DC)
	Caution of high voltage		Protective ground
	Turn on or turn off the UPS		Recycle
	Alternating current source (AC)		Do not dispose with ordinary trash

3. Introduction

This On-Line series is an uninterruptible power supply incorporating double-converter technology. It provides reliable protection, specifically designed for computer equipment, communication servers, and data centres.

The double-converter principle eliminates all mains power disturbances. A rectifier converts the alternating current from the mains power to direct current. Using this DC voltage, the inverter generates an AC sinusoidal voltage, which constantly supplies the loads. In the event of power failure, the maintenance-free batteries power the inverter.

This manual covers the UPS listed below. If your UPS is not listed please contact your dealer for an appropriate replacement.

Model No.	Type	Model No.	Type
C500-060-B	Standard	C500-060-C	Extended backup time
C500-100-B		C500-100-C	

“C” Model: Extended backup time

3.1 Feature

This unit is a new generation of UPS, which provides outstanding reliability, and the highest cost-performance ratio in the industry. This product has the following benefits:

- True online double-conversion technology with a high power density, frequency independence, and generator compatibility.
- Output power factor is 0.9, pure sine wave output, suitable for almost all critical equipment.
- High input power factor ≥ 0.99 , and overall high efficiency ≥ 0.92 , save power and wiring expenses for the user. Low input current distortion, avoids power pollution.
- N+X parallel redundancy to increase the reliability and flexibility. Number of parallel operating UPS is up to 4.
- HE mode offers a high efficiency (≥ 0.96) which saves power, and, therefore, expense for the user
- Input or output ISO transformer compatibility.
- Start-able without battery.

3.2 Electrical specifications

INPUT

Model No.	C500-060-B(C)	C500-100-B(C)
Phase	Single	
Voltage	176~276VAC	
Frequency	(45~55)/(54~66) Hz	
Current(A)*	25.8	43.0
THDI	< 5% @ full load	
Power Factor	≥0.99 @ full load	

*Rated current while input rated voltage is 230VAC

OUTPUT		
Model No.	C500-060-B(C)	C500-100-B(C)
Power rating	6kVA/5.4kW	10kVA/9kW
Voltage	208*/220/230/240× (1 ± 1%) VAC	
Frequency	50/60× (1±0.05) Hz (Battery mode)	
Wave form	sinusoidal	
Load type	PF 0.5~1, lagging	
THDV	< 2% @ full linear load <5% @ full non linear load	
Overload	In Line mode**: 10 min 105~125% 1 min 125~150% 10 s >150% 1 s >170% In Battery mode: 2 min 105~125% 30 s 125~150% 1 s >150%	

*Derating to 90% when the output voltage is adjusted to 208VAC.

**The overload capacity should be derated automatically in Line mode when the temperature is over 35 degrees.

BATTERIES		
Model No.	C500-060-B	C500-100-B
Internal BAT number and type	20×12V 7Ah	20×12V 9Ah
Current of external BAT pack	32Amax	50Amax

3.3 Operating Environment

Operating Temperature	0 °C to 45 °C
Operating humidity	< 95%
Altitude	< 1000m*
Storage temperature	-15 °C to 50 °C

*The load capacity should be de-rated by 1% for every 100m above 1000m (above sea level)

3.4 Typical backup time (Typical values at 25°C in minutes)

Model No.	100 % Load
C500-060-B	5
C500-100-B	4.5

3.5 Dimensions and weights

Model No.	Dimensions W×H×D (mm)	Net Weight (kg)
C500-060-B	260 x 708 x 550	80
C500-060-C	260 x 708 x 550	25.5
C500-100-B	260 x 708 x 550	84
C500-100-C	260 x 708 x 550	29.5

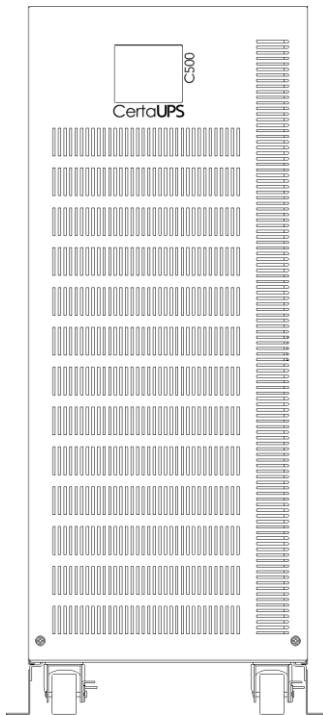

Fig. 3-1 Front view of C500-060-B(C)/ C500-100-B(C)

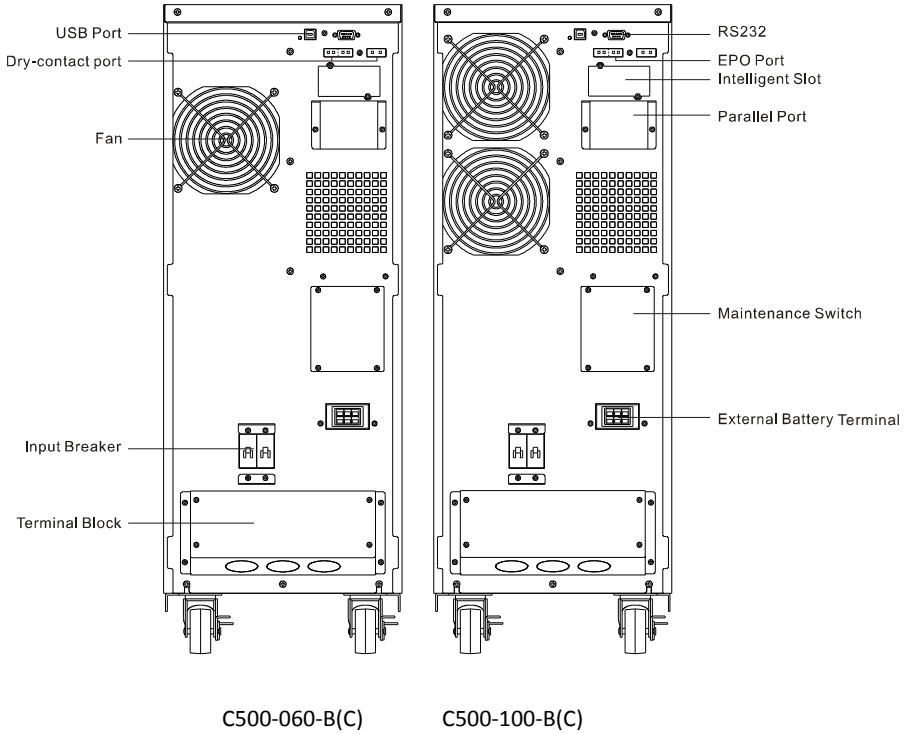

Fig. 3-2 Back View of C500-060-B(C)/ C500-100-B(C)

4. Installation

The system should only be installed and wired by qualified electricians in accordance with applicable safety regulations!

When installing the electrical wiring, please note the nominal amperage of your incoming feeder.

4.1 Moving to the installation site

The C500 series UPS has wheels making it easy to move the UPS to the installation site after it has been unpacked. However, if the receiving area is far from the installation site, it is recommended to move the UPS by using a pallet jack or a truck before unpacking the UPS.

4.2 Unpacking and inspection

1. At the installation site, the utmost care should be taken when removing all packaging in order to avoid damaging the equipment. Cut the plastic poly-straps around the shipping container and remove the corrugated carton and the PS foam on the top of the UPS. With one or two people on each side of the UPS, lift the UPS out of the pallet.

Warning: the plastic poly-straps around the shipping container are under tension. While cutting these straps take great care as they may spring back and cause injury



The shipping materials are recyclable. After unpacking, dispose of them appropriately.

-
2. Check all packaging materials to ensure that no items are missing. The shipping package contains:
 - A UPS
 - A user manual
 - A parallel cable
 - A parallel port cover plate
 - A Dry contact connector
 - An EPO connector
 3. Inspect the appearance of the UPS to see if there has been any damage incurred during transportation. If there is any damage apparent DO NOT turn on the unit. Notify the carrier and dealer immediately of any damage.

4.3 Input and output power wires and protective earth ground installation

4.3.1 Notes for installation

- 1) The UPS must be installed in a location with good ventilation, away from sources of water, inflammable gas and corrosive agents.
- 2) Ensure the air vents on the front and rear of the UPS are not obstructed. Allow at least 0.5m of space on each side.
- 3) If the UPS is unpacked in a very low temperature environment it is possible that condensation may form internally. In this case it is necessary to wait until the UPS is fully dried inside out before proceeding with installation and use. Any moisture could cause a potential hazard.
- 4) The additional side mounting brackets (optional accessory) can be fixed to obtain greater stability of the UPS enclosure. See Fig. 4-5.

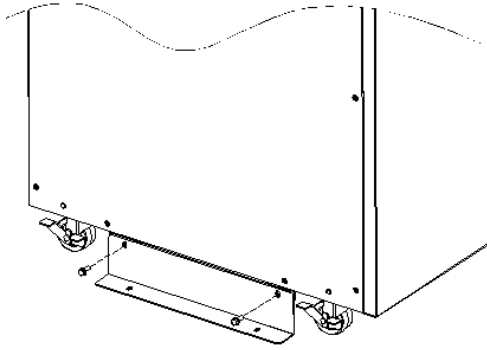

Fig. 4-5 Additional stability

4.3.2 Installation

For safety reasons, please disconnect the mains power switch before installation

Cable specifications to be used when installing the unit:

Model	C500-060-B	C500-100-B
Protective earthing conductor Min cross section	6mm ² (8AWG)	10 mm ² (6AWG)
Input L, N, G Min conductor cross section	6mm ² (8AWG)	10 mm ² (6AWG)
Input breaker	40A/250VAC	63A/250VAC
Output L,N, Min conductor cross section	6mm ² (8AWG)	10 mm ² (6AWG)
External Battery Cabinet Positive Pole(+), Negative pole(-), Neutral Pole Min conductor cross section	6mm ² (8AWG)	10 mm ² (6AWG)
External Battery Cabinet Fuse in Positive Pole(+), Negative pole(-), Neutral Pole	30A/240VDC	60A/240VDC

External Battery Cabinet Breaker in Positive Pole(+), Negative pole(-), Neutral Pole	32A/240VDC	50A/240VDC
Torque for fixing above terminals	3.95~4.97Nm (35~44 lb in)	

- 1) It is suggested to install an external isolating device to protect against current backfeed between mains input and the UPS (see Fig.4-6). After the device is installed, an appropriate warning should be applied to the external AC converter label reading:

‘RISK OF VOLTAGE BACKFEED’

Isolate the UPS before operating on this circuit, then check for hazardous voltage between all terminals prior to starting work.

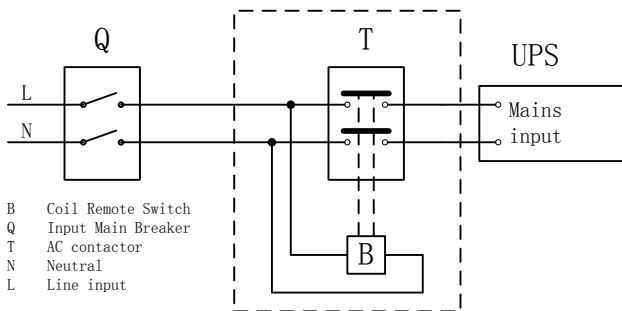

Fig.4-6 Typical external isolating device installation

- 2) The parts inside the unit may still have hazardous voltage after turning off the UPS. To turn off the UPS output, power off the UPS, and then cut off the mains power supply, wait for the UPS shut down completely.
- 3) Open the terminal block cover located on the rear panel of the UPS, please refer to the layout diagram.
- 4) For 6KVA UPS, it is recommended to select the UL1015 8AWG/6mm² or other insulated wire which complies with AWG Standard for the UPS input and output wirings.

- 5) For 10KVA UPS, it is recommended to select the UL1015 6AWG/10mm² or other insulated wire which complies with AWG Standard for the UPS input and output wirings.
- 6) Ensure that the mains supply has a large enough rating. This rating should be higher than the maximum requirement of the UPS. Failure to comply with this requirement could cause major damage if the current ratings are exceeded.
- 7) The protective earth ground wire should be installed first. Only appropriate cablings should be used.
- 8) Connect other input and output wires to the corresponding input and output terminals according to the diagram below.
- 9) Ensure that the terminal connectors are firmly fastened to be sure of a safe and reliable connection.

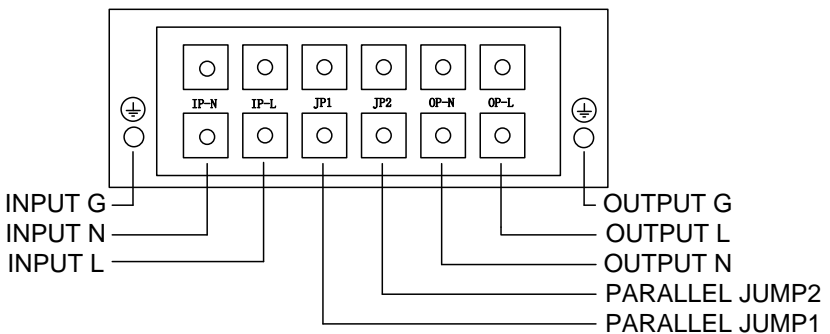

Fig. 4-7 Input and output Terminal Block wiring diagram

Important notes: If the UPS is used in single mode, JP1 and JP2 must be connected. If the UPS is used in parallel mode, the Jumper between JP1 and JP2 must be removed.

- 10) An output breaker should be installed between the output of the UPS and the load. This breaker should protect against excessive leakage current.

-
- 11) When using the UPS for the first time all load should be removed prior to switching the unit on. Once on, loads should be added gradually one by one.
 - 12) After completing the installation, check all the wires are connected correctly and tightly.
 - 13) It is recommended that the batteries used in this system are charged for a minimum of 8 hours prior to use. The UPS can be used immediately without the recommended 8 hour initial charge. However, this will have the effect of reducing the backup time compared to the standard rating.
 - 14) If it is necessary to connect an inductive load (such as a monitor or a laser printer) to the UPS, the start-up power should be used for calculating the required capacity of the UPS.

4.4 Operating procedure for connecting with the external battery

1. The nominal DC voltage of the external battery pack is 240VDC. Each battery pack consists of 20 pieces of 12V maintenance free batteries in series. To achieve longer backup time, it is possible to connect multi-battery packs, but the principle of “same voltage, same type” should be strictly followed.
2. For 6KVA, select the UL1015 8AWG/6mm² or other insulated wire which complies with AWG Standard for the UPS battery wirings.
3. For 10KVA, select the UL1015 6AWG/10mm² or other insulated wire which complies with AWG Standard for the UPS battery wirings.
4. The two UPS units MUST NOT share the same external battery pack.
5. The procedure for installing the battery pack should be followed strictly. Otherwise there is a risk of electric shock.
 - 1) Ensure the UPS is not powered on and the mains input breaker is set in the “OFF” position.

- 2) A DC breaker must be installed between the external battery pack and the UPS. The capacity of the breaker must be not less than that shown in the data specified in the general specification.
- 3) Set the external battery pack breaker to the “OFF” position and connect the batteries in series.
- 4) Connect the external battery pack to the battery terminals. Check the polarity of the connection is correct.
- 5) Set the battery pack breaker to the “ON” position.
- 6) Set the mains input breaker to the “ON” position. The UPS should power on and start to charge the battery pack.

4.5 EPO Connection

4.5.1 Introduction

The emergency power off function (EPO) built into this model of UPS is designed to allow the user to integrate the UPS into an emergency EPO system. The connector on the back of the unit (shown below) is used for connecting into the EPO system.

4.5.2 The connection

Normally the EPO connector is closed with a wire on the rear panel, which is supplied as an accessory. Once the connector is open, the UPS will stop the output and enter EPO status.

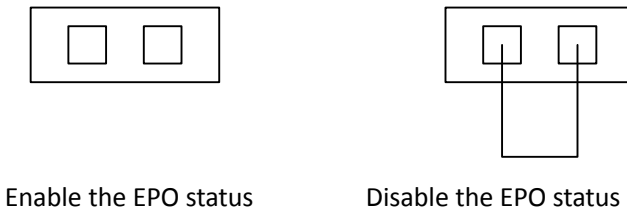

Fig. 4-8 Default EPO status

To return to normal status, first close the EPO connector. Once the connector has been closed it is necessary to clear the EPO status through the LCD screen, instructions on doing this are available in chapter 5.

5. Operation

5.1 Display Panel

The UPS has a four-button dot matrix LCD with dual colour backlight. The

standard back-light is used to light up the display with white text and a blue background. When the UPS has a critical alarm, the backlight changes the text to dark amber and the background to red. Besides the LCD, the UPS has four coloured LEDs to provide more convenient information.

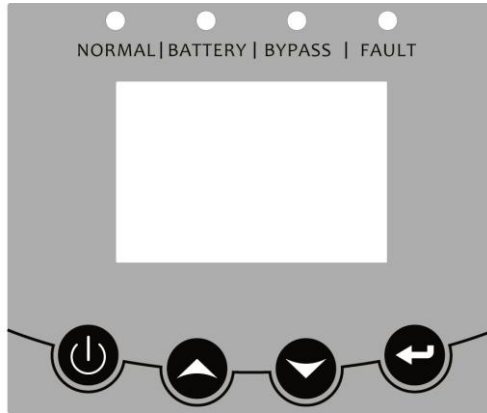



Fig. 5-1 Control Panel

Table 5-1 Control Button Functions

The Button	Function	Illustration
	Power on	When the unit is without power and has connected with battery, press this button for >100ms&<1s to power on
	Turn on	When the unit is powered on and in Bypass mode, press this button for >1s to turn on
	Turn off	When the unit has been turned on, press this button for >3s to turn off
	Enter main menu	When displaying default UPS status summary screen, press this button for >1s to enter the main menu tree
	Exit main menu	Press this button for >1s to exit the present menu to default system status display menu without executing a command or changing a setting



	Scroll up	Press this button for >100ms&<1s to scroll up the menu option
	Scroll down	Press this button for >100ms&<1s to scroll down the menu option
	Enter next menu tree	Press this button for >100ms&<1s to select the present menu option, or enter next menu, without changing any setting
	Select one menu option	Press this button for >100ms&<1s to select the present menu option, or enter next menu, without changing any setting
	Confirm the present setting	Press this button for >1s to confirm the edited options and change the setting

Table 5-2 LED definition

UPS state	Normal LED (Green)	Battery LED (Yellow)	Bypass LED (Yellow)	Fault LED (Red)
Bypass mode with no output			★	↑
Bypass mode with output			●	↑
Turning on	△	△	△	△
Line mode	●			↑
Battery mode	●	●		↑
HE mode	●		●	↑
Battery test mode	△	△	△	△
Fault mode			↑	●
Warning	↑	↑	↑	★

Note:

- : Lightened constantly
- △: #1-#4 Lightened circularly

★: Flashing

↑: Depended on the fault/warning status or other status

Table 5-3 Buzzer definition

UPS condition	Buzzer status
Fault active	Continuous
Warning active	Beep every second
Battery output	Beep every 4 seconds, if battery low, buzzer Beep every second
Bypass output	Beep every 2 minutes
Overload	Beep twice every second

The UPS provides useful information about the UPS itself, load status, events, measurements, identification, and settings through the front panel display.

After powering on, the LCD will display the logo for several seconds and then go to the default page which shows the UPS status summary.

The display automatically returns to the default UPS status summary screen when no button has been pressed for 15 minutes.

On the UPS status summary screen it provides the following information:

- Status summary, including mode and load
- Alarm status, if any are present
Notes: alarm including fault and warning information
- Battery and charger status, including battery voltage, charge level and charger status
- Running information including parallel UPS and running time

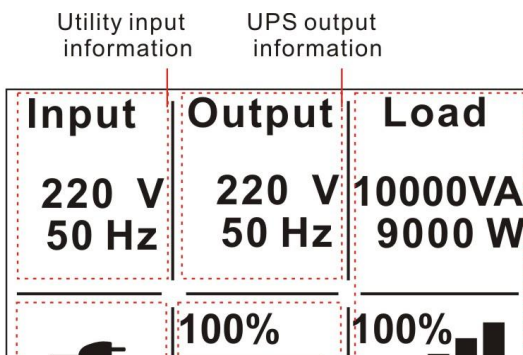

Fig. 5-2 The default LCD display

The more detailed operation of the LCD is illustrated in chapter 5.5.

5.2 Operating mode

The different graphic symbols are displayed corresponding to current operating mode or status.

5.2.1 Line mode

An example of LCD display in Line mode is shown in the following diagram.

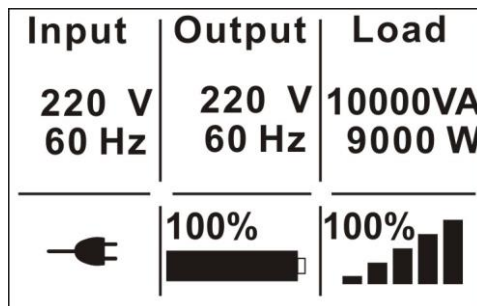

Fig. 5-3 Line mode

5.2.2 Battery mode

An example showing the LCD display in battery mode is shown in the following diagram.

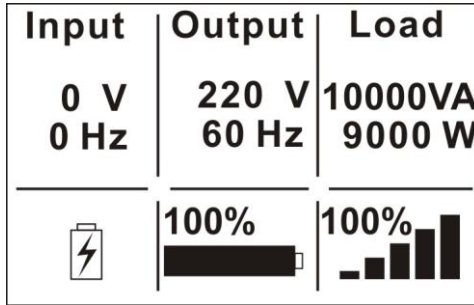

Fig. 5-4 Battery mode

When the UPS is running in battery mode, the buzzer beeps once every 4 seconds.

5.2.3 Bypass with output

The LCD display in bypass mode with output is shown in the following diagram. The UPS does not have the backup function when it is in bypass mode. The power used by the load is supplied from the mains power via an internal filter. The UPS will beep once every 2 minutes in bypass mode.

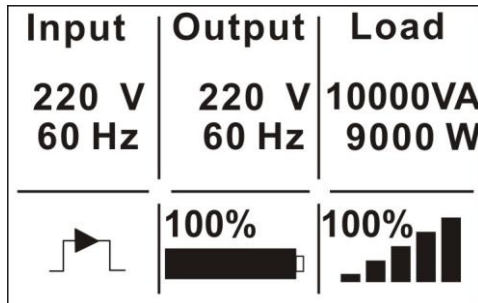

Fig. 5-5 Bypass mode with output

5.2.4 Bypass without output

The LCD display in bypass mode without output is shown in the following diagram.



Input	Output	Load
220 V 60 Hz	0 V 0 Hz	0VA 0 W
	100% 	0% 

Fig. 5-6 Bypass mode without output

5.2.5 HE mode (High Efficiency mode)

HE mode is a mode of operation offering outstanding efficiency and, therefore, lower running costs to the user. This mode is sometimes referred to as 'Eco mode'

After the UPS is turned on, the power used by the load is supplied from the mains power via the internal filter while the mains power is in normal range, so the high efficiency can be gained in the HE mode. Once the mains power is lost or abnormal, the UPS will transfer to Line mode or Battery mode and the load is supplied continuously.



Input	Output	Load
220 V 60 Hz	220 V 60 Hz	10000VA 9000 W
	100% 	100% 

Fig. 5-7 HE mode

- 1) The function can be enabled through the LCD setting or the software provided.
- 2) It should be noted that the transfer time of UPS output from HE mode to battery mode is approximately 10ms. This is acceptable for a majority of loads, although for some more sensitive loads it could represent a problem.

5.2.6 Converter mode

In converter mode, the UPS will run with fixed output frequency (50Hz or 60Hz). Once the mains power is lost or abnormal, the UPS will transfer to battery mode and the load is supplied continuously.



Input	Output	Load
220 V 50 Hz	220 V 60 Hz	6000VA 5400 W
	100% 	100% 

Fig. 5-8 Converter mode

- 1) The function can be enabled through the LCD setting or the software provided.
- 2) The load should be de-rated to 60% in converter mode.

5.2.7 Warning

When the warning occurs, it shows that there are some abnormal problems during the operation of the UPS. Normally the problems are not serious and the UPS continues working, but they should be addressed, or the UPS may fail.

The detailed warning table is shown in chapter of 7.



Input	Output	Load
220 V 60 Hz	220 V 60 Hz	10000VA 9000 W
	100% 	100% 

Fig. 5-9 Warning

5.2.8 Fault

When the fault occurs, it shows that some serious problem has happened; the UPS will directly cut off the output or transfer to bypass, and keep alarming. The backlight of LCD will also turn to red.

The detailed fault table is shown in chapter 7.



Input	Output	Load
220 V 60 Hz	0 V 0 Hz	0VA 0 W
	100% 	0% 

Fig. 5-10 Fault

5.2.9 Other status

When the UPS is overloaded, the alarm will beep twice every second. Some unnecessary loads should be removed one by one to decrease the load connected to the UPS to less than 90% of its nominal power capacity.

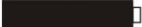
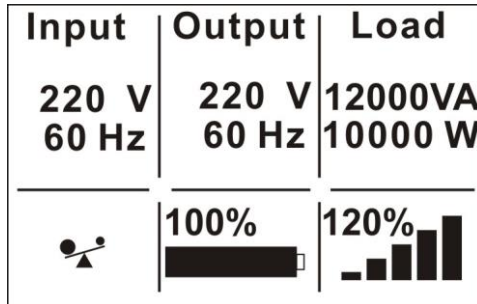

Fig. 5-11 Overload

While doing the battery test, the battery test symbol will be shown on the display.

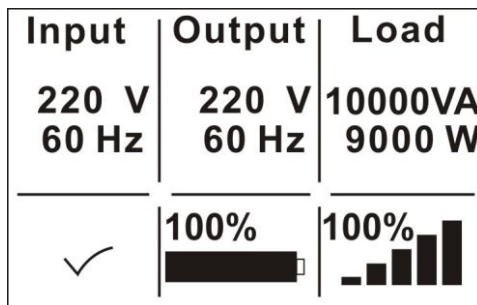

Fig. 5-12 Battery test

If the battery status detected is “bad battery detected” or “battery disconnected”, the battery failure symbol will be shown and the UPS will alarm.

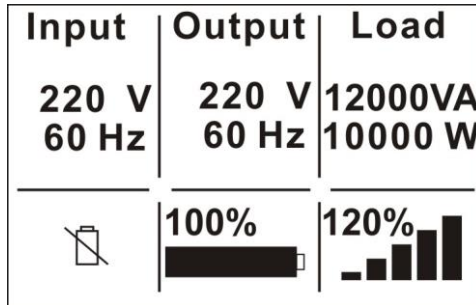



Fig. 5-13 Battery Fails



5.3 Turning on and Turning off UPS

Warning: Please switch off the connected loads first before turning on the UPS, and switch on the loads one by one after the UPS is turned on. Switch off all of the connected loads before turning off the UPS.

5.3.1 Turning on UPS with mains

- 1) Check all the connections are correct. Check the external battery pack breaker is in “ON” position.
- 2) Set input breaker to “ON” position. At this time the fan begins to rotate and the LCD screen will show the logo. Then LCD will show the default UPS status summary screen after the UPS finishes the self-test.
- 3) By pressing  button continuously for more than 1 second, the buzzer will beep for 1s and the UPS will start to turn on.
- 4) A few seconds later, the UPS turns into Line mode. If the mains power is abnormal, the UPS will transfer to Battery mode without output interruption.

5.3.2 Turning on UPS without mains

- 1) Check all the connections are correct. Check the external battery pack breaker is in “ON” position.
- 2) By pressing  button continuously for more than 100ms, the UPS will be powered on. At this time the fan begins to rotate and the LCD will show the logo. Then LCD will show the default UPS status summary screen after the UPS finishes the self-test.
- 3) By pressing  button continuously for more than 1 second, the buzzer will beep 1s, the UPS starts to turn on.
- 4) A few seconds later, the UPS turns into Battery mode. If the mains power comes back, the UPS will transfer to Line mode without output interruption.

5.3.3 Turning off UPS with mains

- 1) To turn off the UPS inverter press  button continuously for more than 3 seconds and the buzzer will beep 3s. The UPS will then turn into Bypass mode.



-
- 2) When completing the above action, the UPS output voltage is still present. In order to cut off the UPS output, simply cut off the mains power supply. A few seconds later, the LCD display shuts down and no output voltage is available from the UPS output terminal.

5.3.4 Turning off UPS without mains

- 1) To power off the UPS press  button continuously for more than 3 seconds, and the buzzer will beep 3s. The UPS will cut off the output at once.
- 2) A few seconds later, LCD shuts down and no voltage is available from the UPS output.

5.4 LCD operation

5.4.1 The main menu

In the default UPS status summary screen, when pressing  or  <1s, the detailed information about the alarm, the parallel system and the battery will be shown.

In the default UPS status summary screen, when pressing  >1s, the display will enter the main menu tree.

The main menu tree includes six branches: UPS status menu, event log menu, measurement menu, control menu, identification menu and setting menu.

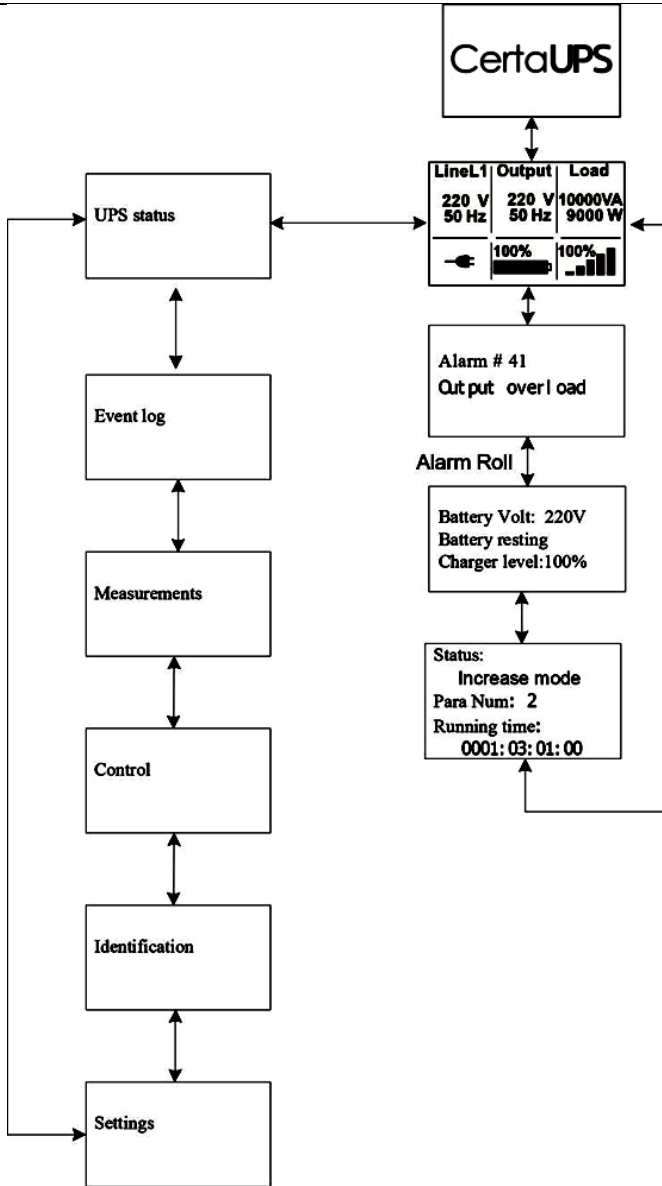

Fig. 5-14 Main menu tree

5.4.2 The UPS status menu

By pressing \leftarrow on the menu of “UPS status”, the display will enter the next UPS status menu tree.

The content of the UPS status menu tree is the same as the default UPS status summary menu.

By pressing \uparrow >1s, the display will return to the last main menu tree.

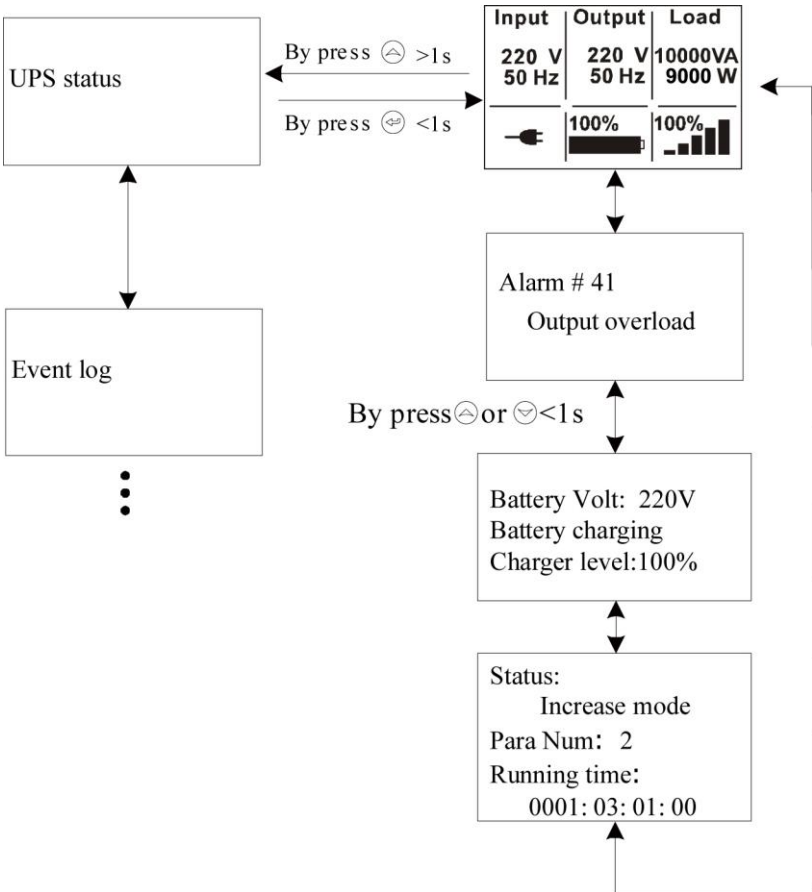





Fig. 5-15 UPS status menu tree

5.4.3 The event log menu

By pressing  on the “Event log” menu, the display will enter the next event menu tree.

All the old events, alarms and faults have been recorded here. The information includes the illustration, the event code, and the operating time of the UPS when the event happened. By pressing  or  <1s, all the events can be displayed one by one.

The max number of records is 50. When the number is larger than 50, the oldest one will be overwritten by the newest event.

By pressing  >1s, the display will return the last main menu tree.

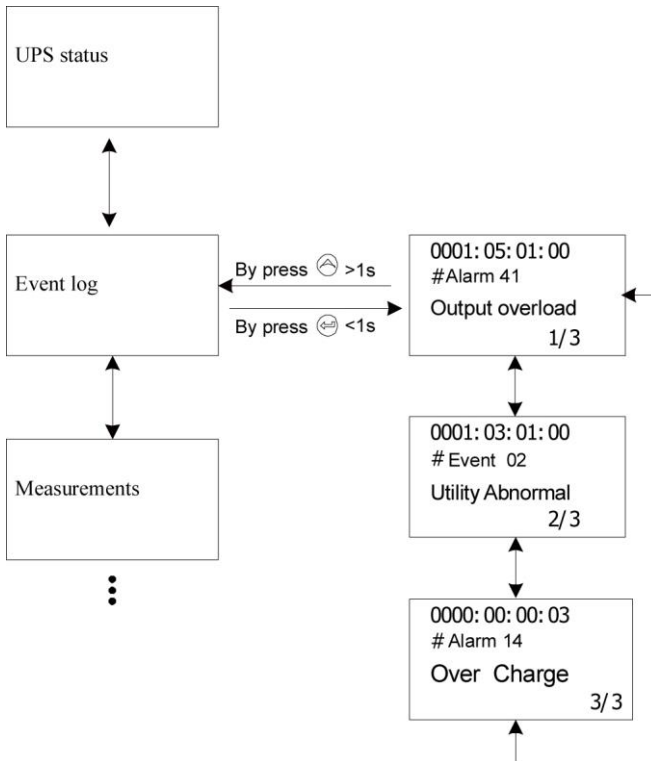



Fig. 5-16 Event menu tree

5.4.4 The measurement menu

By pressing  on the “Measurement” menu, the display will enter the next measurement menu tree.

A lot of detailed useful information can be checked here, for example the output voltage and frequency, the output current, the load capacity, the input voltage and frequency.

By pressing  >1s, the display will return to the last main menu tree.

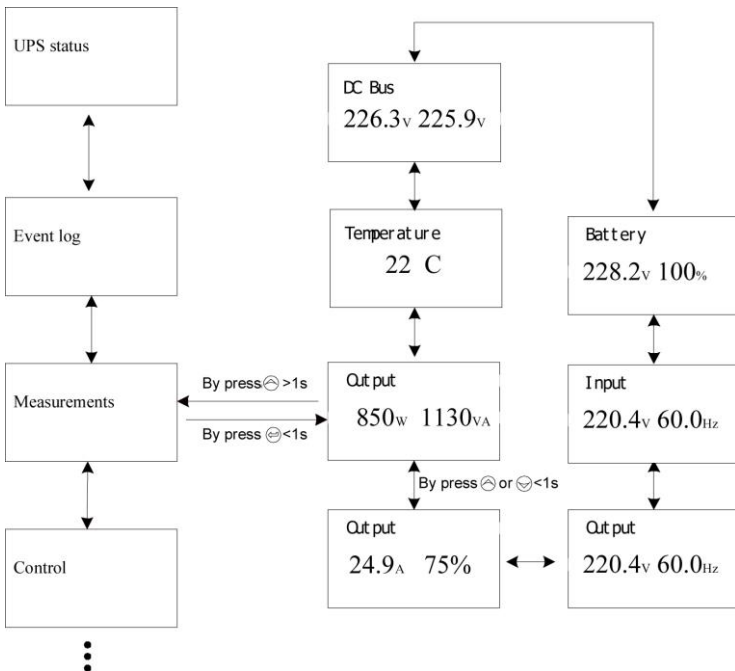



Fig. 5-17 Measurement menu tree

5.4.5 The control menu

By pressing  on the “Control” menu, the display will enter the next control menu tree.

- 1) The “Single UPS turn off” command is designed to turn off one UPS which is currently operated in a parallel redundancy system. All other UPSs continue working to supply the load in the parallel system.
- 2) The “Single UPS battery test” command is designed to control one UPS which is currently operated in a parallel system for single battery testing. The other UPSs do not do the battery test.
- 3) The “Parallel UPS battery test” is designed to control all UPS in a parallel system to do the battery test at the same time.
- 4) “Clear EPO status” once EPO status is enabled, the UPS output will be cut off. To recover to normal status, first the EPO connector should be closed, and enter this menu to clear EPO status, then the UPS will stop the alarm and recover to Bypass mode. The UPS should be turned on by manual operation.
- 5) “Reset Fault status” when a fault occurs, the UPS remains in Fault mode and alarms. To recover to normal status, enter this menu to reset error status, then the UPS will stop the alarm and recover to Bypass mode. The cause of the fault should be checked and dealt with before the UPS is turned on again by manual operation.
- 6) Restore factory settings: all the settings can be recovered to default factory settings. This can only be done in Bypass mode.

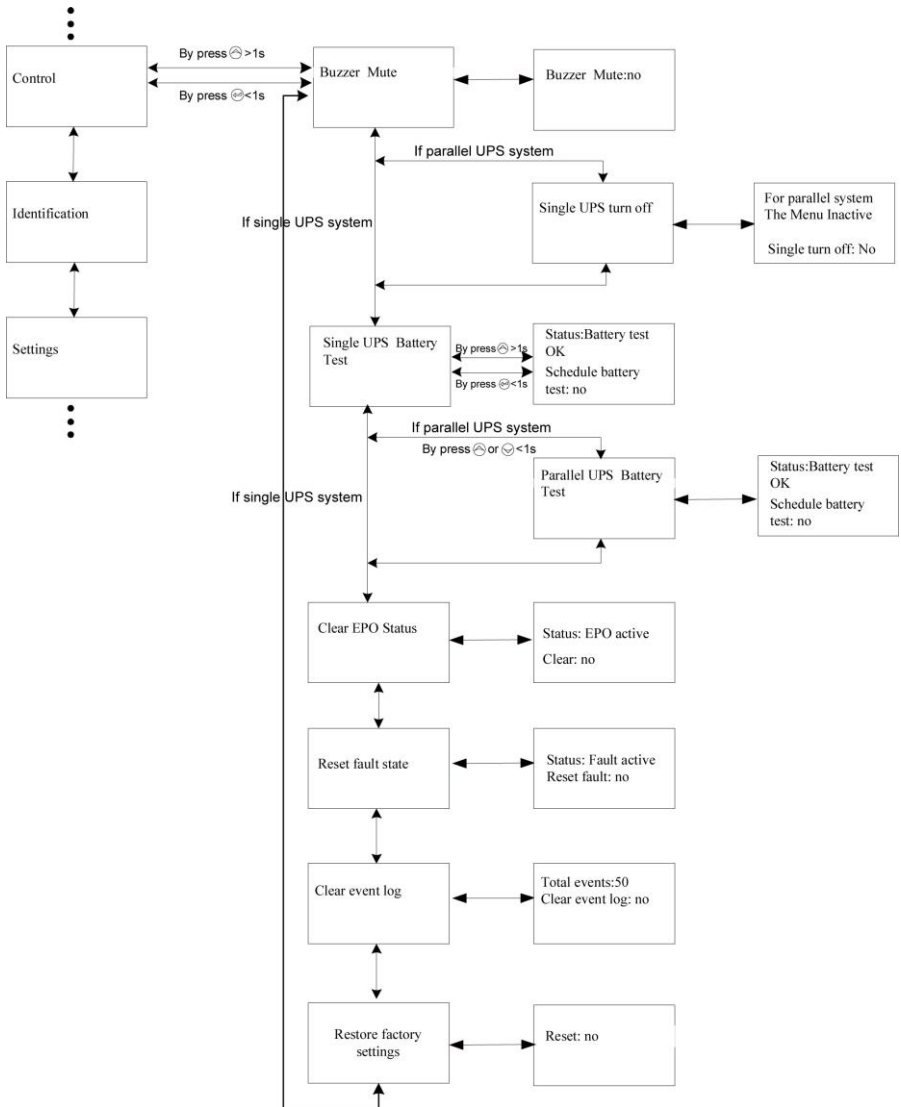



Fig. 5-18 Control menu tree

5.4.6 The identification menu

By pressing  on the “Identification” menu, the display will enter the next identification menu tree.

The identification information includes UPS serial number, firmware serial number and model type.

By pressing  >1s, the display will return to the last main menu tree.

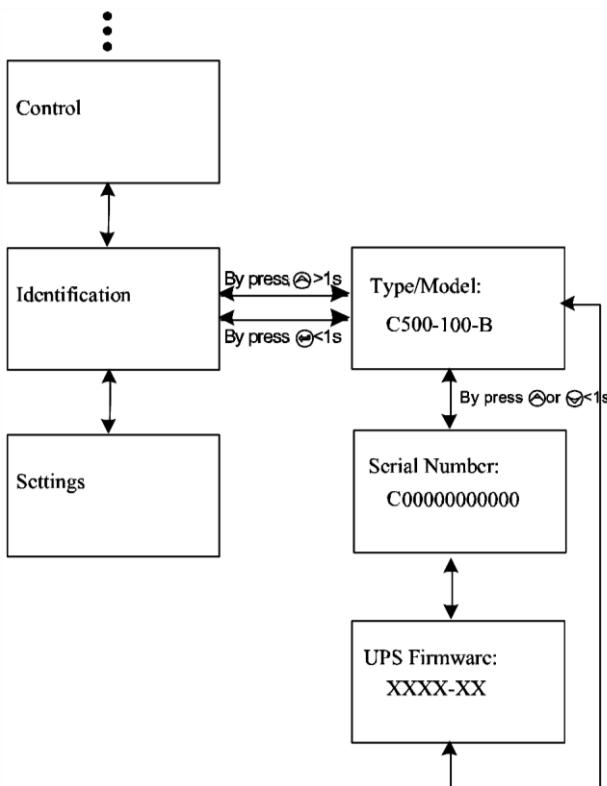

Fig. 5-19 Identification menu tree

6. Special function

The C500 series UPS has some features, which could provide for special user applications. These functions have their own features, please contact your local distributor for further information.

6.1 HE function

6.1.1 Brief introduction of HE function

If the HE function is enabled, the power used by the load is supplied directly from the mains power via an internal filter whilst the utility power is in normal range. This enables the high efficiency to be gained in HE mode. HE mode is sometimes referred to as “Eco mode”. Once the mains power is lost or abnormal, the UPS will transfer to Line mode or Battery mode and the load is supplied continuously.

This system results in an overall high efficiency ≥ 0.96 of UPS, this will save power for the user.

Due to the load being connected directly to the mains supply the protection provided does not include any form of isolation. This means that any mains spikes etc. that are on the mains supply are passed through to the equipment connected.

This method of operation, whilst offering exceptional efficiencies, will take approximately 10ms to switch to the battery mode. This means that whilst this mode of operation is suitable for a majority of loads, it could prove to be unsuitable for highly sensitive loads and for areas with highly unstable mains supply.

6.1.2 Set the function

The function could be enabled through the LCD setting in Bypass mode. Enter the power strategy setting menu by following chapter of 5.5.7.

6.2 Converter function

6.2.1 Brief introduction of Converter function

In converter mode, the UPS will free run with fixed output frequency (50Hz or 60Hz). Once the mains power is lost or abnormal, the UPS will transfer to Battery mode and the load is supplied continuously.

The main advantage of this mode is the output frequency is fixed. This can be required for some particularly sensitive loads.

This additional protection means that the load capacity of the UPS should be reduced to 60% when used in converter mode.

6.2.2 Set the function

This function could be enabled through the LCD setting in Bypass mode. Enter the power strategy setting menu by following chapter of 5.5.7.

6.3 Parallel function

6.3.1 Brief introduction of the redundancy

$N+X$ is currently the most reliable power supply structure. N represents the minimum UPS number that the total load needs, X represents the redundant UPS number, i.e. the fault UPS number that the system can handle simultaneously. When the X is larger, the reliability of the power system is higher. For occasions where reliability is highly depended on, $N+X$ is the optimal mode.

As long as the UPS is equipped with parallel cables, up to 4 UPSs can be connected in parallel to realize output power sharing and power redundancy.

6.3.2 Parallel installation and operation

How to install a new parallel UPS system:

- 1) Before installing a new parallel UPS system, the user needs to prepare the input and output wires, the output breaker, and the parallel cable.
- 2) Users should use the provided parallel cable with these units wherever possible. If the provided cable is not suitable for the needs of the user, a cable of the same or higher specification should be used.
- 3) Remove the cover plate of the parallel port on the UPS, connect each UPS one by one with the parallel cables, and attach the Parallel port cover which is supplied in the accessories.
- 4) Follow strictly the instructions in chapter 4 for the wiring of each UPS.
- 5) Connect the output wires of each UPS to an output breaker panel.
- 6) Disconnect the Jumper on JP1 and JP2 of the terminal block first, and connect each output breaker to a main output breaker and then to the loads.
- 7) Each UPS needs an independent battery pack.
- 8) Please refer to the wiring diagram (Fig 6-1).
- 9) The distance between the UPSs in parallel and the breaker panel must be less than 20 meters. The difference between the input and output wires of the UPSs must be less than 20%.

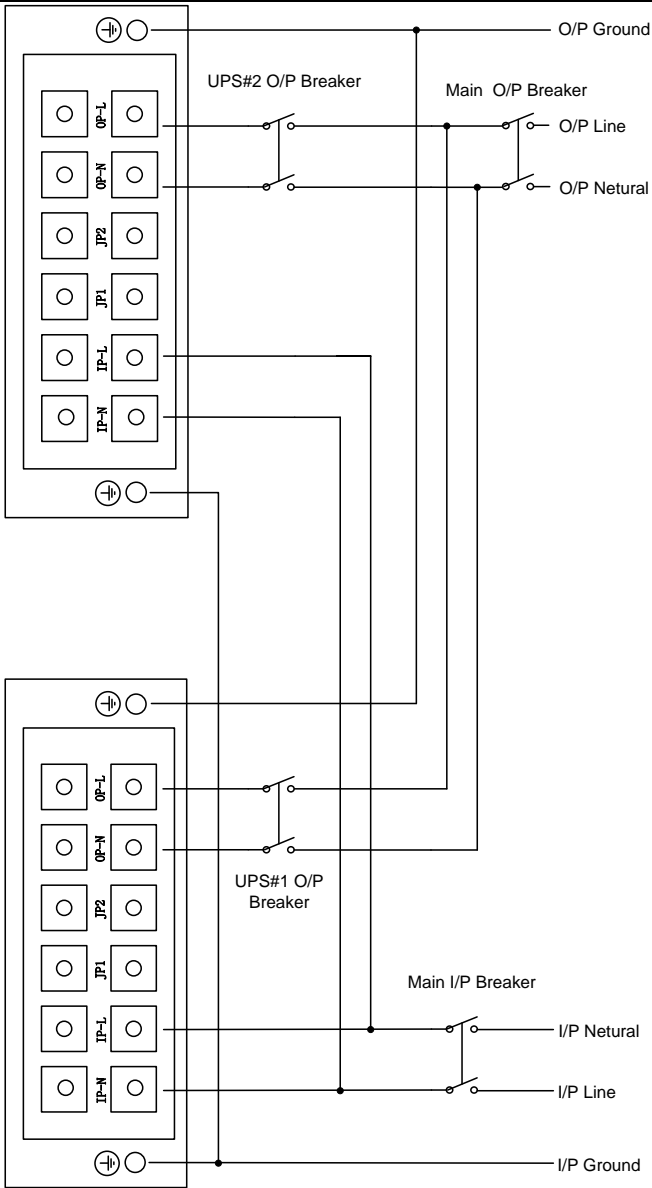

Fig. 6-1 Input and output Terminal Block wiring diagram

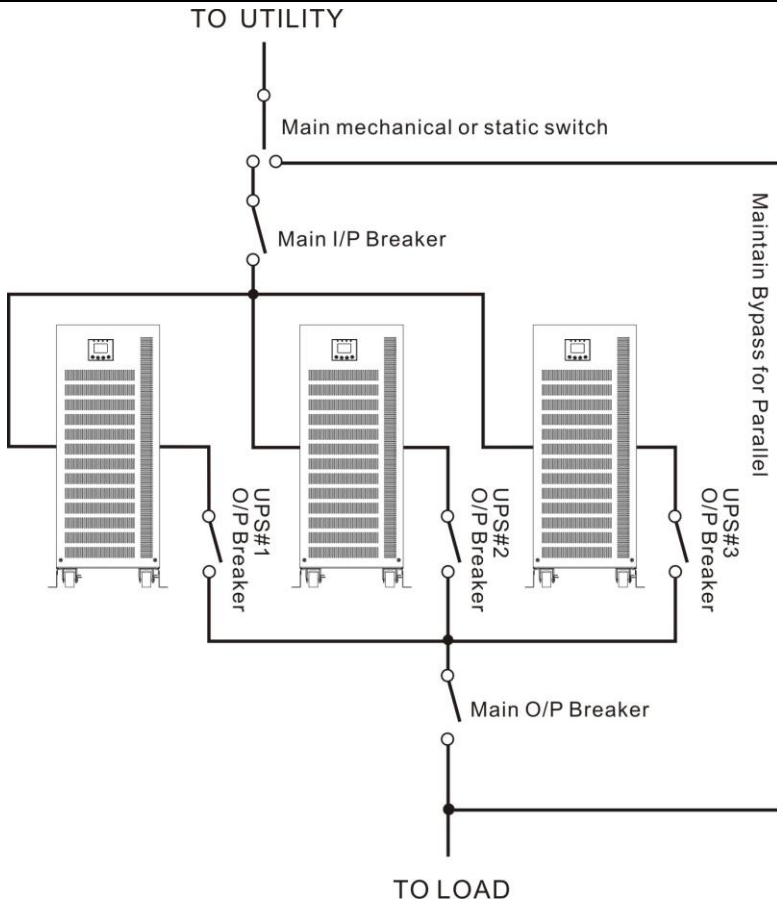





Fig. 6-2 Parallel System Installation Diagram

- 10) With the output breakers of each unit switched OFF, switch on the input breaker. Look at the LCD screen and check for any displayed fault information.

Once done, check and note each UPS output voltage independently. If the voltage difference between the unit is less than 1V then proceed. If not check the wiring.

-
- 11) Press the  button of one UPS, each UPS will start to turn on and all the UPSs will transfer to the INV mode together. Measure the output voltage of each UPS separately to check if the voltage difference between them is less than 0.5V. If the difference is more than 0.5V, the UPS need to be regulated.
 - 12) Press the  button of one UPS, each UPS will turn off and transfer to the Bypass mode. Once off, switch on the output breaker of each UPS to parallel.
 - 13) Press the  button of one UPS, each UPS will start to turn on. After turning on, the UPSs should work in parallel in the Line mode.

How to join a new UPS to a parallel system:

- 1) First the parallel system must be installed with a main maintenance mechanical switch or static switch.
- 2) Regulate the output voltage of the new UPS separately: check if the output voltage difference between the new UPS and the parallel system is less than 0.5V.
- 3) Ensure the bypass of the parallel system is normal and the bypass setting is “enable”. Remove the cover plate of maintenance switch on the rear panel of each UPS. The UPS system will transfer to bypass automatically. Set the maintenance switch for each UPS from “UPS” to “BPS”.
- 4) Set the main maintenance switch or static switch from “UPS” to “BPS”, switch off the main output breaker and the main input breaker. The UPS will shut down.
- 5) Ensure the UPSs shut down totally. Add the new UPS and reinstall the new UPS parallel system by following step 1) to 9) of last chapter - “install a new parallel UPS system”.

- 6) Switch on the main input breaker and the main output breaker, and set the main maintenance switch or static switch from “BPS” to “UPS”, then set the UPS’s own maintenance switch from “BPS” to “UPS” and screw the maintenance cover plate back again. Press the  button of one UPS, each UPS will start to turn on. After turning on, the UPSs should work in parallel in the Line mode.

How to remove a single UPS from a parallel system:

- 1) First the parallel system must be installed with a main maintenance mechanical switch or static switch.
- 2) Ensure the bypass is normal and the bypass is set to “enable”. Remove the maintenance switch cover plate on the rear panel of each UPS. The UPS system will transfer to bypass automatically. Set the maintenance switch of each UPS from “UPS” to “BPS”.
- 3) Set the main maintenance switch or static switch from “UPS” to “BPS”. Switch off the main output breaker and the main input breaker, and the UPS will shut down.
- 4) Ensure the UPSs is shut down totally. Remove the UPS and reinstall the new UPS by following step 1) to 9) of last chapter - “install a new parallel UPS system”.
- 5) If the removed UPS or the remaining UPS will be used in stand-alone mode, then JP1 and JP2 on the terminal block should be connected with a short connection wire.
- 6) Switch on the main input breaker and the main output breaker, and set the main maintenance switch or static switch from “BPS” to “UPS”, then set the UPS’s maintenance switch from “BPS” to “UPS” and screw the maintenance cover plate back again. Press the  button of one UPS, each UPS will start to turn on. After turning on, the UPSs will work in parallel in the Line mode.

7. Trouble Shooting

If the UPS system does not operate correctly, first check the operating information on the LCD display.

Please attempt to solve the problem using the table below. If the problem still persists, consult your dealer.

7.1 Trouble Shooting According To Warning Indication

Problem Displayed	Possible cause	Remedy
Read EEPROM Error	UPS internal fault	Consult dealer.
Epo Active	EPO connector is open	Check the EPO connector status
On Maintain Bypass	Maintain bypass switch is open	Check the maintain bypass switch status
Site Wiring Fault	Phase and neutral conductor at input of UPS system are reversed	Reverse mains power wiring.
Battery Disconnect	Battery pack is not connected correctly	Do the battery test to confirm. Check the battery bank is connected to the UPS. Check the battery breaker is turned on.
Battery low	Battery voltage is low	When audible alarm sounding every second, battery is almost empty.
Output Overload	Overload	Check the loads and remove some non-critical loads. Check if some loads are failed.
Fan Failure	Fan abnormal	Check if the fan is running normally.
Charger Fail	The charge fails	Consult dealer.
Battery Over Voltage	Battery voltage is higher than normal value	Check if the battery quantity is right.
Over Charge	Battery is over charged	The UPS will turn off the charger until the battery voltage is normal
Model Pin Error	UPS internal fault	Consult dealer.

Ambient Over Temperature	The ambient temperature is too high	Check the environment ventilation.
Heatsink Over Temperature	Inside temperature of UPS is too high	Check the ventilation of UPS and the ambient temperature.
Ambient NTC abnormal	UPS internal fault	Consult dealer.
Para Cable Male Loss	The parallel cable is disconnected	Check the parallel cable.
Para Cable Female Loss	The parallel cable is disconnected	Check the parallel cable.
Para Bat Differ	The battery packs of some UPSs are disconnected	Check if all the battery pack is connected.
Para Line Differ	The mains input of some UPSs is disconnected	Check the building wiring and input cable. Check if the input breaker is closed. Ensure the UPSs are connected to same input source.
Para Work Mode Differ	There are different power strategy setting in parallel system	The UPSs with different power strategy setting (Ex. one Line mode and one Converter mode) are forbidden to parallel.
Para Rate Power Differ	There are different UPSs in parallel system	The UPSs with different capacity (Ex. one 6KVA and one 10KVA) are forbidden to parallel.
HE In Para	HE function is enabled in parallel system	HE function is forbidden in parallel system.

7.2 Trouble Shooting According To Fault Indication

Problem Displayed	Possible cause	Remedy
Inv Overload Fault	Overload	Check the loads and remove some non-critical loads. Check if some loads are failed.
Byp Overload Fault	Overload	Check the loads and remove some non-critical loads.

		Check if some loads are failed.
Output Short Circuit	Output short circuit	Remove all the loads. Turn off the UPS. Check if UPS output and loads is short circuit. Ensure short circuit is removed before turning on again.
Heatsink Over Temperature Fault	Inside temperature of UPS is too high	Check the ventilation of UPS and the ambient temperature.
Bus Over Voltage	UPS internal fault	Consult dealer.
Bus Under Voltage	UPS internal fault	Consult dealer.
Bus Unbalance	UPS internal fault	Consult dealer.
Bus short	UPS internal fault	Consult dealer.
Bus Softstart Fail	UPS internal fault	Consult dealer.
Inv Over Voltage	UPS internal fault	Consult dealer.
Inv Under Voltage	UPS internal fault	Consult dealer.
Inv Softstart Fail	UPS internal fault	Consult dealer.
Negative Power Fault	The load is pure inductive and capacitive	Remove some non-critical loads. Bypass supplies the load first, ensure there is no overload, then turn on UPS.
Cable male and female Loss fault	The parallel cable is disconnected	Check the parallel cable.

7.3 Trouble Shooting In Other Cases

Problem	Possible cause	Remedy
No indication, no warning tone even though system is connected to mains power supply	No input voltage	Check the building wiring and input cable. Check if the input breaker is closed.
BYPASS LED light up even though the power supply	Inverter not switched on	Press On-Switch "I" to turn on UPS.

is available		
BATTERY LED lights up, and audible alarm sounding every 1 beep in every 4 seconds	Input voltage and/or frequency are out of tolerance	Check input power source. Check the building wiring and input cable. Check if the input breaker is closed.
Emergency supply period shorter than nominal value	Batteries not fully charged / batteries defect	Charge the batteries for at least 12 hours and then check capacity.

Please have the following information at hand before calling the After-Sales Service Department:

1. Model number, serial number
2. Date on which the problem occurred
3. LCD/LED display information, Buzzer alarm status
4. Mains power condition, load type and capacity, environment temperature, ventilation condition
5. The information (battery capacity, quantity) of external battery pack if the UPS is "S" model
6. Other information for complete description of the problem

8. Battery Maintenance

Battery replacement should be performed by qualified personnel.

- This series of UPS only requires minimal maintenance. The batteries used for standard models are regulated sealed lead-acid maintenance free. These models require minimal repairs. The only requirement is to charge the UPS regularly in order to maximize the expected life of the battery. When connected to the utility power, whether the UPS is turned on or not, the UPS keeps charging the

batteries and also offers overcharging and over-discharging protection.

- The UPS should be charged once every 4 to 6 months if it has not been used within this time frame.
- In hot climates, the battery should be charged and discharged every 2 months. The standard charging time should be at least 12 hours.
- Under normal conditions, the battery life is 3 to 5 years. Unusual or extreme operation may cause a shortening of battery life. If batteries are discovered to have reached the end of their usable lives replacement should be made as soon as possible.
- Replace batteries with the same number and same type of batteries.
- Do not replace the batteries individually. All the batteries should be replaced at the same time following the instructions of the battery supplier.
- If the battery service life (3~5 years at 25°C ambient temperature) has been exceeded, the batteries must be replaced.

9. Communication Port

9.1 USB Interface

The USB port is compliant with USB 1.1 protocol for its communication software.

9.2 RS-232 Interface

The RS-232 port is available for UPS monitoring, control, and firmware updates.

The cable pins for the RS-232 communication port are identified in the following illustration.

RS-232 communication port pin assignments

Pin	Signal name	Function	Direction from the
-----	-------------	----------	--------------------

			UPS
1		Unused	Not applicable
2	Tx	Transmit to external device	Out
3	Rx	Receive from external device	In
4		Unused	Not applicable
5	GND	Signal common	Not applicable
6		Unused	Not applicable
7		Unused	Not applicable
8		Unused	Not applicable
9		Unused	Not applicable

9.3 Dry contact Interface

The UPS incorporates built-in single programmable relay output with potential free contact for remote alarm indication: Dry out port which incorporates a single signal input: Dry in port. See figure in the UPS rear panel for the locations of the ports.

The relay output can be configured by the protocol command setting, the default output contact is "Summary Alarm"; The signal input to control the UPS On/Off status does not need to be configured. Its function is the same as one button to control the UPS On/Off status.

Note: The relay output contact must not be connected to any utility connected circuits. Reinforced insulation to the utility is required.

The relay output contact has a maximum rating of 30Vac/1A and 60Vdc/2A normal values.

The following figures show schematics of the dry out/in contacts.

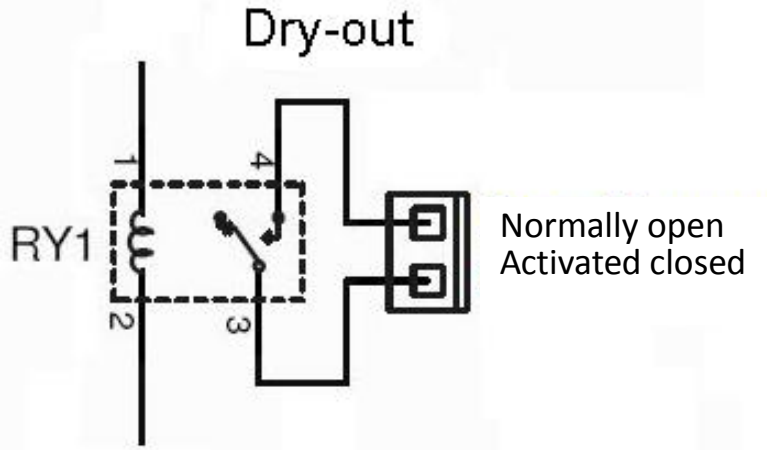

Dry out contact schematic

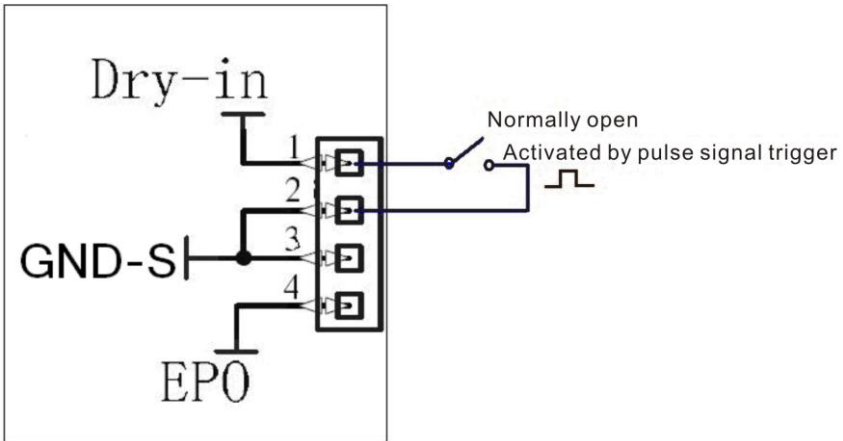

Dry in contact schematic

The following table shows the options for the dry out/in contacts

Dry out signal	Description
Summary Alarm	Activated when any warning happens
On Battery	Activated when the UPS operates on battery
Battery Low	Activated with the “bLOW” alarm
UPS ok	Activated when the UPS has no alarms and no fault.
On Bypass	Activated when the UPS has bypass output.
Dry in signal	Description
UPS Off/On	Activated by >100ms pulse, the UPS turns off when the UPS is on inverter; the UPS turns on when it is not on inverter. It is the same as a remote button to control UPS On/Off status.
Maintain bypass	Activated by >100ms pulse, the UPS will turn to bypass mode and warning when it is activated, just like maintain switch action. The warning will disappear if the trigger pulse disappeared for one second.

9.4 Intelligent slot

This series is equipped with an intelligent slot for other optional cards to achieve remote management of the UPS through internet / intranet. Please contact your local distributor for further information.

10. Software

Free Software Download – WinPower

WinPower is UPS monitoring software, which provides user-friendly interface to monitor and control UPSs. This unique software provides auto shutdown for multi-computer systems during power failure. With this software, users can monitor and control any UPS on the same LAN, as a local computer through RS232 or USB protocol, no matter how far from the UPS.

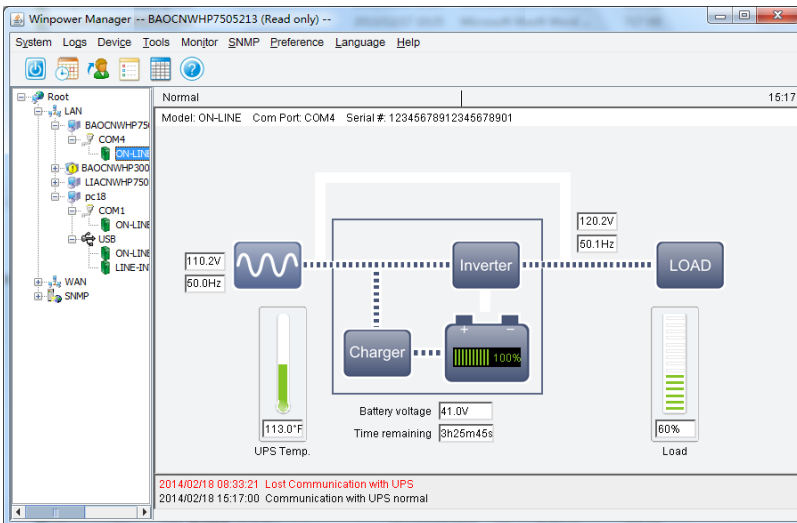

Installation procedure:

1. Go to the website:
<http://www.certaups.com/software>
2. Choose the operating system you need and follow the instructions described on the website to download the software.
3. When downloading all required files from the internet, enter the product key: **511C1-01220-0100-478DF2A** to install the software.

When the computer restarts, the WinPower software will appear as a green plug icon located in the system tray, near the clock.